

Hybrid Fiber/Coax Systems

Traditional Cable Architecture - Coax “Tree-and-Branch”

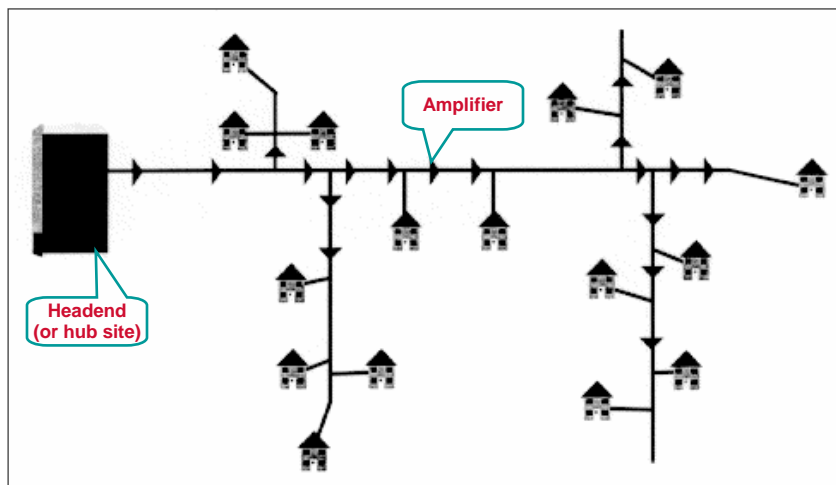

Typically 25-30 amplifiers in cascade

Source: General Instrument

Modern Hybrid Fiber-Coax (HFC) Architecture

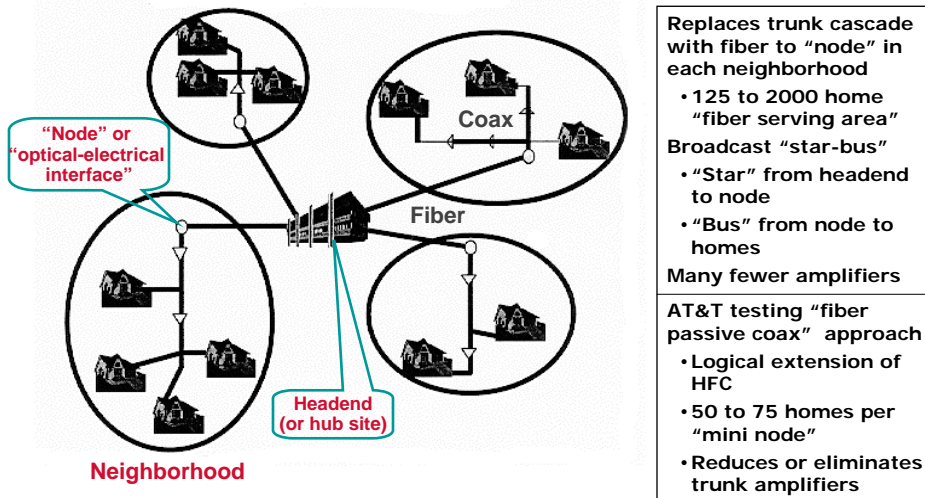

Replaces trunk cascade with fiber to "node" in each neighborhood

- 125 to 2000 home "fiber serving area"

Broadcast "star-bus"

- "Star" from headend to node
- "Bus" from node to homes

Many fewer amplifiers

AT&T testing "fiber passive coax" approach

- Logical extension of HFC
- 50 to 75 homes per "mini node"
- Reduces or eliminates trunk amplifiers

Source: General Instrument

Transmitter based on DFB Laser

- Linearity of the Laser

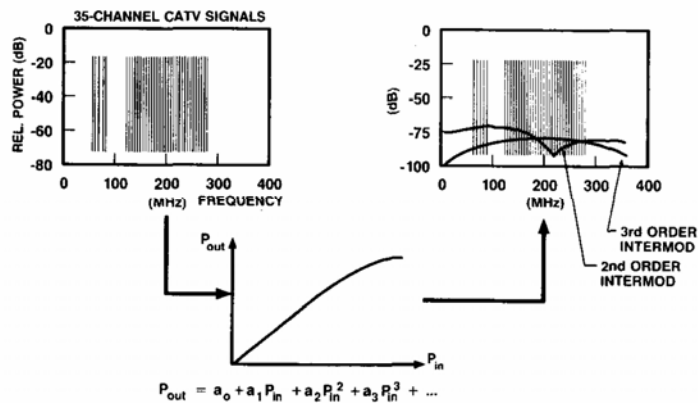

Transmitter based on External Modulator

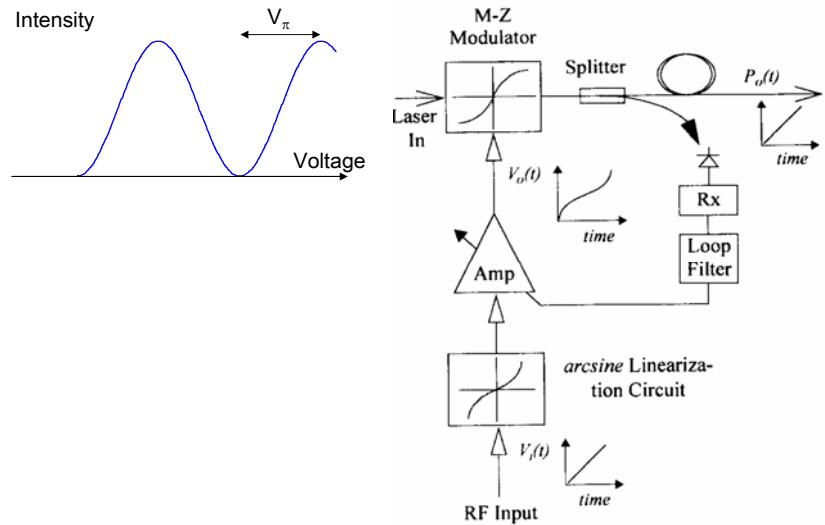

What is CSO and CTB?

- CSO: Composite Second Order
- CTB: Composite Triple Beat
- Both must be less than 65 dBc

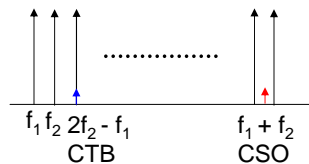

Clipping Distortion/Saleh Limit

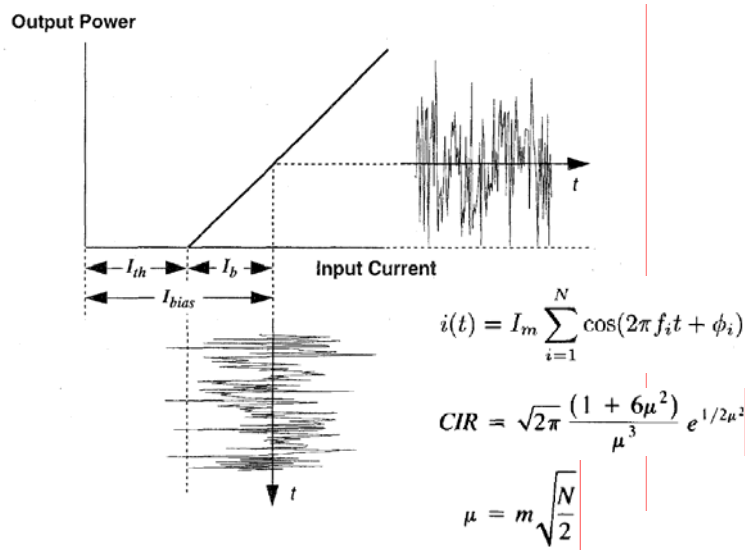

CSO and CTB w/ Clipping

$$R_{in}(\tau) = \frac{1}{2} I_m^2 \sum_{i=1}^N \cos(2\pi f_i \tau)$$

$$R_{out}(\tau) = \sum_{n=0}^{\infty} \frac{b_n^2}{\sigma^{2n}} [R_{in}(\tau)]^n$$

$$b_n = \frac{1}{\sqrt{2\pi}\sigma n!} \int_{-\infty}^{\infty} g(x) e^{-x^2/2\sigma^2} H_n\left(\frac{x}{\sigma}\right) dx$$

K.-P. Ho and J. M. Kahn, IEEE PTL 8 (1996) 125.

System Design

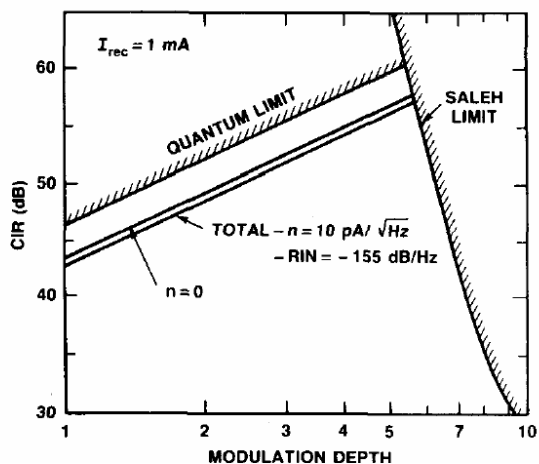

Bi-directional w/ Digital Channels

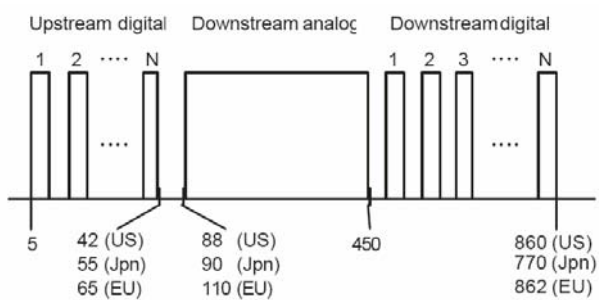

Clipping Distortion to Digital Channels

- Impulse noise

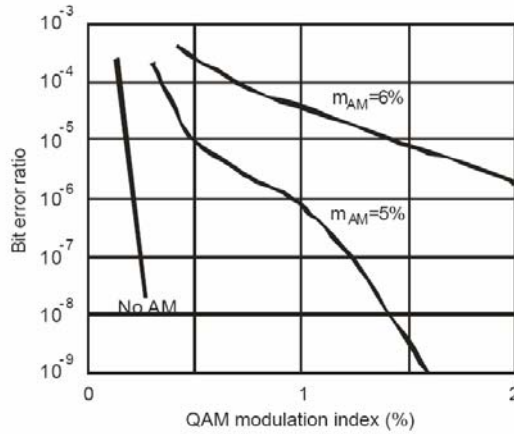

Ingress Noise for Upstream Signal

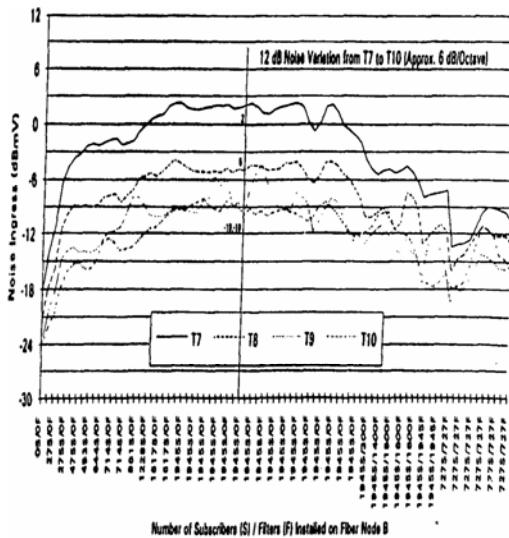

Table 2. Background noise power density in dBm/Hz.

Location	8 kHz - 2 MHz
Mount. View	-134
Farmingdale	-148
Fair Haven	-123

Ingress Noise

