

2.7 Test methods for polarization mode dispersion

2.7.1 The Jones matrix eigenanalysis technique

2.7.1.1 General

This test method describes a procedure for measuring the Polarization Mode Dispersion (PMD) of single-mode optical fibres. The measurement result is obtained from a single series of Jones matrix measurements performed at intervals across a wavelength range. It can be applied to both short and long fibres, regardless of the degree of polarization mode coupling. Under some circumstances, repeated measurements may be necessary to achieve satisfactory precision. This method is restricted to wavelengths greater than or equal to that at which the fibre is effectively single-mode.

2.7.1.2 Test apparatus

See Figure 22 for a schematic diagram of the key components in a typical measurement system.

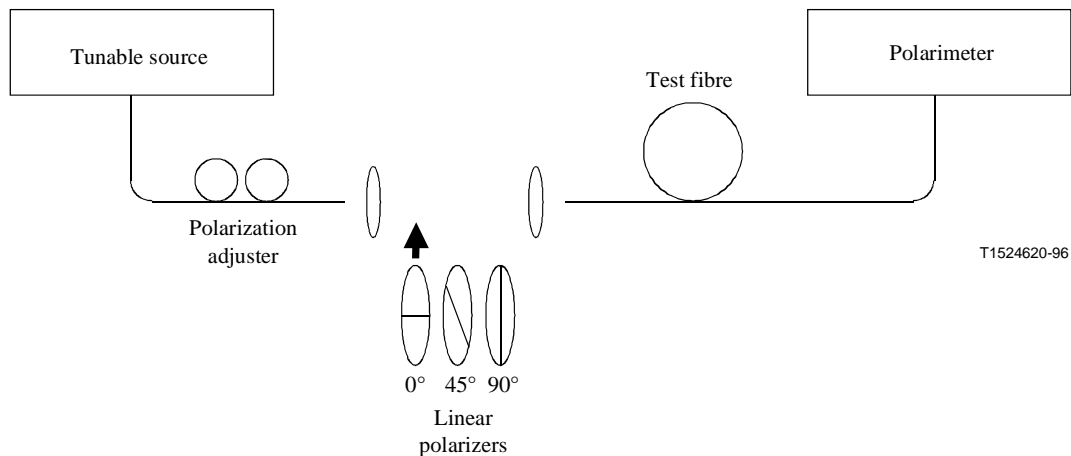

Figure 22/G.650 – Schematic diagram of equipment (typical)

2.7.1.2.1 Light source

Use a single-line laser or narrow-band source which is tunable across the intended measurement wavelength range. The spectral distribution shall be narrow enough so that the light emerging from the test fibre remains polarized under all conditions of the measurement. Degree of Polarization (DOP) of 90% or greater is preferred, although measurements may be performed with values as low as 25% with reduced precision. For a given value of differential group delay $\Delta\tau$, the lowest degree of polarization which can result is given by:

$$DOP = 100e^{-\frac{1}{4\ln 2} \left(\frac{\pi c \Delta\tau \Delta\lambda_{FWHM}}{\lambda_0^2} \right)^2} \quad (2-26)$$

assuming a Gaussian spectrum of width $\Delta\lambda_{FWHM}$ centred at λ_0 . DOP is expressed in per cent.

2.7.1.2.2 Polarization adjuster

A polarization adjuster follows the laser and is set to provide roughly circularly polarized light to the polarizers, so that the polarizers never cross polarization with their input light. Adjust polarization as follows. Set the tunable laser wavelength to the centre of the range to be measured. Insert each of the three polarizers into the beam and perform three corresponding power measurements at the output of

the polarizers. Adjust the source polarization via the polarization adjuster such that the three powers fall within approximately a 3 dB range of one another. In an open beam version of the set-up, a waveplate may perform the polarization adjustment.

2.7.1.2.3 Polarizers

Three linear polarizers at relative angles of approximately 45 degrees are arranged to be inserted into the light beam in turn. The actual relative angles shall be known.

2.7.1.2.4 Input optics

An optical lens system or single-mode fibre pigtail may be employed to excite the test fibre.

2.7.1.2.5 Fibre pigtail

If pigtails are used, interference effects due to reflections should be avoided. This may require index matching materials or angled cleaves. The pigtails shall be single-mode.

2.7.1.2.6 Optical lens system

If an optical lens system is used, some suitable means, such as a vacuum chuck, shall be used to stably support the input end of the fibre.

2.7.1.2.7 Cladding mode stripper

Remove any cladding mode power from the test fibre. Under most circumstances, the fibre coating will perform this function; otherwise, employ a device that extracts cladding mode power.

2.7.1.2.8 Output optics

Couple all power emitted from the test fibre to the polarimeter. An optical lens system, a butt splice to a single-mode fibre pigtail or an index-matched coupling made directly to the detector system are examples of means that may be used.

2.7.1.2.9 Polarimeter

Use a polarimeter to measure the three output states of polarization corresponding to insertion of each of the three polarizers. The wavelength range of the polarimeter shall include the wavelengths produced by the light source.

2.7.1.3 Measurement procedure

The test sample shall be a known length of a single-mode optical fibre which may or may not be cabled. The sample and pigtails shall be fixed in position at a nominally constant temperature throughout the measurement. Temperature stability of the test device may be observed by viewing the output state of polarization of the test fibre on a Poincare sphere display. In a time period corresponding to an adjacent pair of Jones matrix measurements, output polarization change should be small relative to the change produced by a wavelength increment.

NOTE – Although the test sample is normally a fibre, this test can also be performed on discrete components. In this case, PMD coefficient is not relevant.

When it is important to minimize additional mode coupling, uncabled fibre shall be supported in some manner (usually on a reel having a minimum wind radius of 150 mm) with essentially zero fibre tension (typically less than 15 g).

Alternative fibre conditions (e.g. fibre shipping spool) may be used in case it has been demonstrated that comparable results are obtained.

Couple the light source through the polarization adjuster to the polarizers.

Couple the output of the polarizers to the input of the fibre under test.

Couple the output of the fibre under test to the input of the polarimeter.

Select the wavelength interval $\Delta\lambda$ over which Jones matrix measurements are to be performed. The maximum allowable value of $\Delta\lambda$ (around λ_0) is set by the requirement:

$$\Delta\tau_{\max}\Delta\lambda \leq \frac{\lambda_0^2}{2c} \quad (2-27)$$

where $\Delta\tau_{\max}$ is the maximum expected DGD within the measurement wavelength range. For example, the product of maximum DGD and wavelength interval shall remain less than 4 ps.nm at 1550 nm and less than 2.8 ps.nm at 1300 nm. This requirement ensures that from one test wavelength to the next, the output state of polarization rotates less than 180 degrees about the principal states axis of the Poincare sphere. If a rough estimate of $\Delta\tau_{\max}$ cannot be made, perform a series of sample measurements across the wavelength range, each measurement using a closely spaced pair of wavelengths appropriate to the spectral width and minimum tuning step of the optical source. Multiply the maximum DGD measured in this way by a safety factor of three, substitute this value for $\Delta\tau_{\max}$ in the above expression and compute the value of $\Delta\lambda$ to be used in the actual measurement. If there is concern that the wavelength interval used for a measurement was too large, the measurement may be repeated with a smaller wavelength interval. If the shape of the curve of DGD versus wavelength and the mean DGD are essentially unchanged, the original wavelength interval was satisfactory.

Gather the measurement data. At the selected wavelengths, insert each of the polarizers and record corresponding Stokes parameters from the polarimeter.

2.7.1.4 Calculations or interpretation of result

2.7.1.4.1 Calculations

From the Stokes parameters, compute the response Jones matrix at each wavelength. For each wavelength interval, compute the product of the Jones matrix $\mathbf{T}(\omega + \Delta\omega)$ at the higher optical frequency and the inverse Jones matrix $\mathbf{T}^{-1}(\omega)$ at the lower optical frequency. Radian optical frequency ω is expressed in radians per second and is related to optical frequency ν by $\omega = 2\pi\nu$. Find the DGD $\Delta\tau$ for the particular wavelength interval from the following expression:

$$\Delta\tau = \left| \frac{\text{Arg}\left(\frac{\rho_1}{\rho_2}\right)}{\Delta\omega} \right| \quad (2-28)$$

where ρ_1 and ρ_2 are the complex eigenvalues of $\mathbf{T}(\omega + \Delta\omega) \mathbf{T}^{-1}(\omega)$ and Arg denotes the argument function, that is $\text{Arg}(\eta e^{i\theta}) = \theta$. For purposes of data analysis, each DGD value is taken to represent the differential group delay at the midpoint of the corresponding wavelength interval. The series of DGD values obtained from a series of wavelength intervals across a wavelength range comprises a single measurement.

2.7.1.4.2 Display of DGD versus wavelength

Data may be plotted in x-y format with DGD on the vertical axis and wavelength on the horizontal axis as shown in Figure 23. Data may also be displayed in a histogram as shown in Figure 24.

Fibre PMD test results
44 km SMF at room temperature

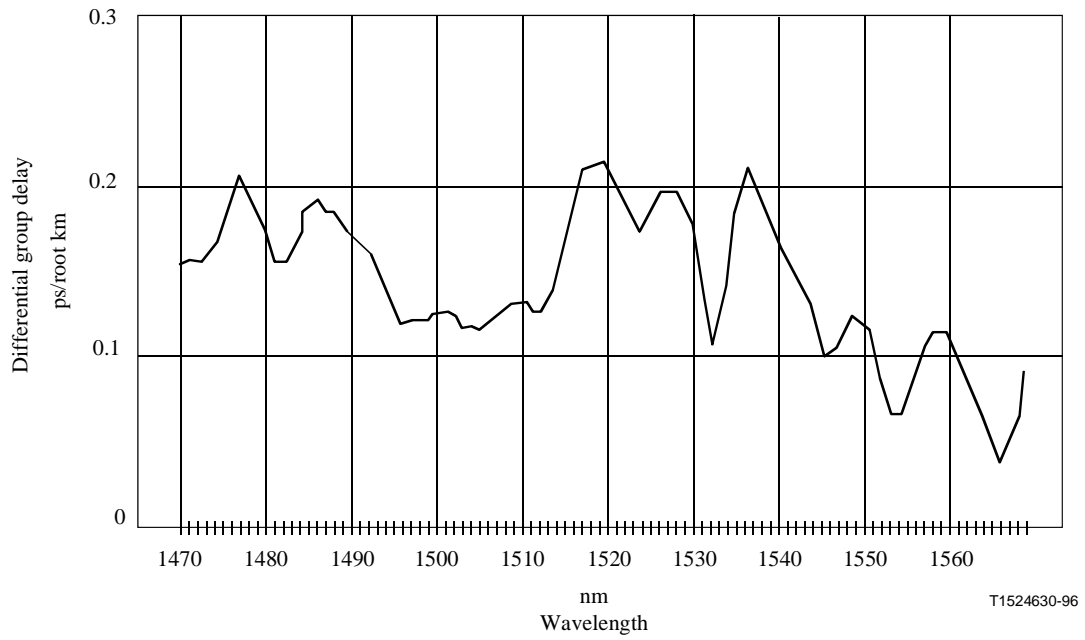
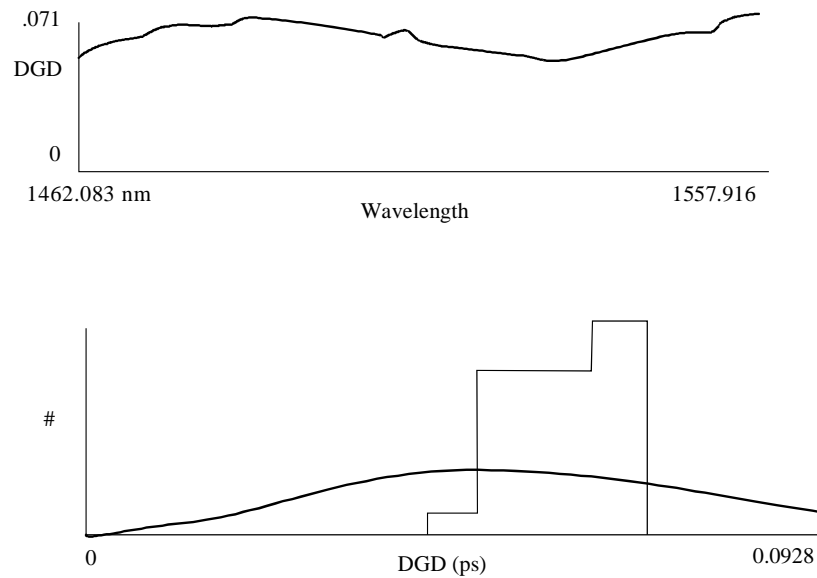
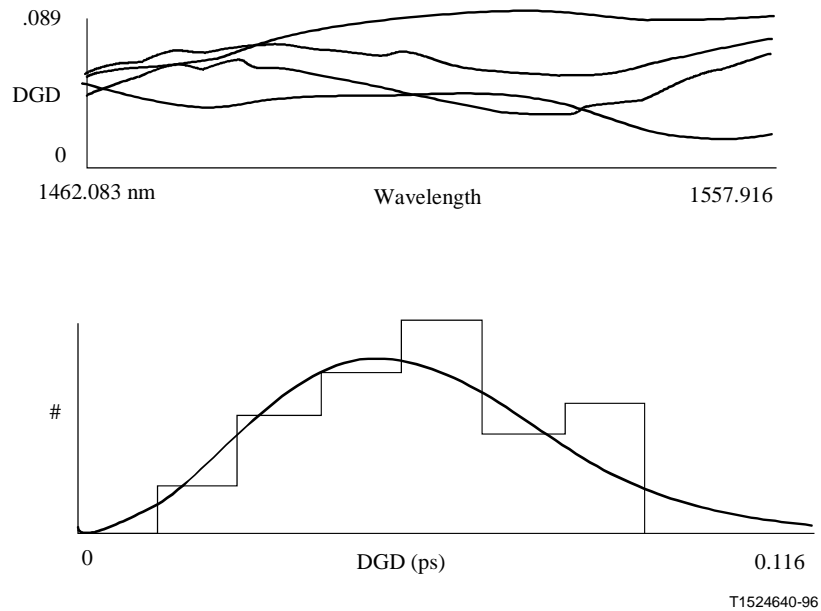

Figure 23/G.650 – Measured DGD of 44 km single-mode fibre



a) Single 24-interval measurement of a spooled fibre



b) Four 24-interval measurements of the same spool conducted at different oven temperatures

Figure 24/G.650 – Examples of DGD data in histogram format

A Maxwell curve is superimposed on each histogram. Curves of measured DGD versus wavelength are shown for reference.

2.7.1.4.3 Average DGD

The expected PMD value $\langle \Delta\tau \rangle_\lambda$ of a single measurement is simply the average of the DGD measurement values corresponding to the wavelength intervals. If multiple measurements are performed under different conditions to increase the sample size, the ensemble average is used.

2.7.1.4.4 PMD coefficient

PMD may be expressed in terms of the short- or long-fibre PMD coefficient, depending upon the type of mode coupling exhibited by the fibre sample. In the absence of mode coupling, use the "short-length" coefficient given in equation 1-9. For fibres with random mode coupling, use the "long-length" coefficient given in equation 1-10.

If the standard deviation of $\Delta\tau$ across the measurement wavelength range is less than 1/10 of the mean, the test fibre is considered to exhibit negligible mode coupling (a "deterministic" device) and PMD may be expressed by the "short-length" PMD coefficient $\langle\Delta\tau\rangle/L$.

2.7.1.4.5 Presentation of the results

- a) Identification of the fibre and/or cable measured.
- b) Test length.
- c) Polarization mode dispersion in ps. If the degree of mode coupling is known, the PMD may be given in ps/km (negligible mode coupling) or ps/km^{1/2} (random mode coupling).
- d) The wavelength range over which the measurement was performed, and the wavelength step size.
- e) The physical configuration of the fibre or cable sample.
- f) Mode coupling type, e.g. deterministic, semi-random or random.
- g) When an average PMD has been determined from repeated measurements of the sample, record the number of measurements performed.
- h) The number of DGD values obtained from a single measurement across the wavelength range, corresponding to the number of wavelength intervals.

2.7.2 The fixed analyser technique

2.7.2.1 General

This test method describes a procedure for measuring the Polarization Mode Dispersion (PMD) of single-mode optical fibres. It produces a single measurement value that represents the PMD over the measurement wavelength range of typically a few hundred nanometers. The method can be applied to both short and long fibres in the limits of both zero and strong polarization mode coupling. Under some circumstances, repeated measurements may be necessary to achieve satisfactory precision using this method. The procedure is restricted to wavelengths greater than or equal to that at which the fibre is effectively single-mode.

2.7.2.2 Test apparatus

See Figure 25 for a schematic diagram of the key components in a typical measurement system.

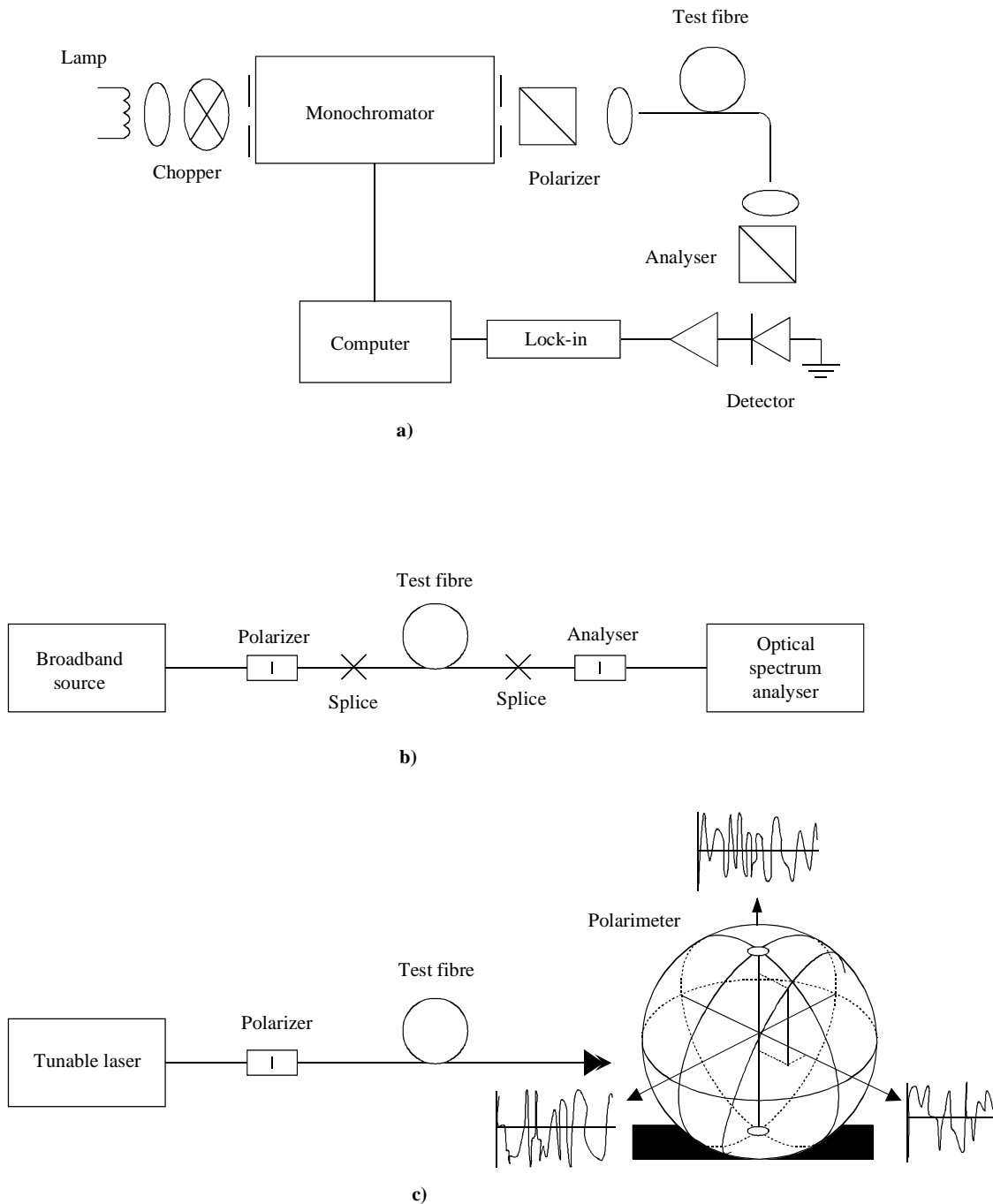

T1524650-96

Figure 25/G.650 – Schematic diagram of equipment (typical)

2.7.2.2.1 Light source

Use a light source which emits radiation at the intended measurement wavelengths, such as a broadband lamp, light emitting diode(s) or tunable laser(s). It shall be stable in intensity and spectral distribution over a time period long enough to perform the measurement.

2.7.2.2.2 Monochromator

Obtain a specified set of test wavelengths by filtering the light source with a monochromator as in Figure 25 a), or by using an optical spectrum analyser as the detector, as in Figure 25 b). This filtering is not needed when the source is a tunable laser [see Figure 25 c)]. The spectral distribution must be narrow enough to avoid major depolarization of the signal under the influence of the PMD of the fibre under test (see 2.7.2.4.1.4 and 2.7.2.4.2.8).

2.7.2.2.3 Input optics

An optical lens system or single-mode fibre pigtail may be employed to excite the test fibre. The power coupled into the fibre shall be stable for the duration of the test. If pigtails are used, interference effects due to reflections should be avoided. This may require index matching materials or angled cleaves. The pigtails shall be single-mode.

If an optical lens system is used, some suitable means, such as a vacuum chuck, shall be used to stably support the input end of the fibre.

2.7.2.2.4 Cladding mode stripper

Remove any cladding mode power from the test fibre. Under most circumstances, the fibre coating will perform this function; otherwise employ a device that extracts cladding mode power.

2.7.2.2.5 Output optics

All power emitted from the test fibre must be coupled onto the active region of the detection system (see Figure 25). An optical lens system, a butt splice to a single-mode fibre pigtail or an index-matched fibre-to-fibre coupling made directly to the detection system are examples of means that may be used.

2.7.2.2.6 Signal detection

For signal detection, use an optical detector which is linear and stable over the range of intensities and measurement times that are encountered in performing the measurement. A typical system might include synchronous detection by a chopper/lock-in amplifier, an optical power meter, an optical spectrum analyser or a polarimeter. To use the entire spectral range of the source, the detection system must have a wavelength range which includes the wavelengths produced by the light source.

2.7.2.2.7 Polarizer and analyser

The polarizer at the fibre input (Figure 25) is needed only if the launch beam is not already polarized (usually a 3 dB extinction ratio is sufficient). The angular orientation of the polarizers is not critical, but should remain fixed throughout the measurement. With weak mode coupling, some adjustment of the polarizer orientation may be helpful in maximizing the amplitude of the oscillations in Figure 26 a). Alternatively, this may be achieved by rotation of the fibre(s) at splices or connectors.

The analyser is not needed when a polarimeter is used for signal detection [Figure 25 c)].

2.7.2.3 Measurement procedure

The test sample shall be a known length of a single-mode optical fibre which may or may not be cabled. The sample and pigtails must be fixed in position at a nominally constant temperature throughout the measurement.

NOTE – Although the test sample is normally a fibre, this test can also be performed on discrete components. In this case, PMD coefficient is not relevant.

Temperature stability of the test device may be observed by measuring the output power from the fibre at a fixed wavelength, with the output analyser in place. In a time period corresponding to a

typical complete measurement, the output power change should be small relative to the changes produced by a wavelength increment.

When it is important to minimize additional mode coupling, uncabled fibre shall be supported in some manner (usually on a reel having a minimum wind radius of 150 mm) with essentially zero fibre tension (typically less than 15 g).

Alternative fibre conditions (e.g. fibre shipping spool) may be used in case it has been demonstrated that comparable results are obtained.

Couple the input end of the fibre to the light source. Couple the output radiation from the fibre under test to the detection system.

By making appropriate adjustments to the monochromator, optical spectrum analyser or tunable laser, inject each designated test wavelength λ in turn into the fibre. The choice of wavelengths depends on the designated wavelength scan range and also on the analysis method (see 2.7.2.4.1 and 2.7.2.4.2).

Record the corresponding output signal for each wavelength. This process shall be accomplished without changing the launch and detector conditions. Call the received power $P_A(\lambda)$, where A denotes the presence of the analyser.

Remove the analyser from the beam and repeat the monochromator scan. Call this received power $P_{TOT}(\lambda)$. This latter power can be used to eliminate the spectral dependence of the measurement system components and the test fibre loss. Typical plots of the ratio:

$$R(\lambda) = \frac{P_A(\lambda)}{P_{TOT}(\lambda)} \quad (2-29)$$

are shown in Figure 26.

An alternative procedure is to leave the analyser in place, but rotate it 90° with respect to the orientation used above. Calling the power received in this case $P_{ROT}(\lambda)$, then:

$$R(\lambda) = \frac{P_A(\lambda)}{P_A(\lambda) + P_{ROT}(\lambda)} \quad (2-30)$$

If a polarimeter is used as the detection element, the normalized Stokes parameters are measured versus wavelength. The three spectral functions are independent of the received power and are analysed by the same methods applied to $R(\lambda)$ (see 2.7.2.4.1 and 2.7.2.4.2). Each normalized Stokes parameter then leads to a value of $\langle \Delta\tau \rangle$.

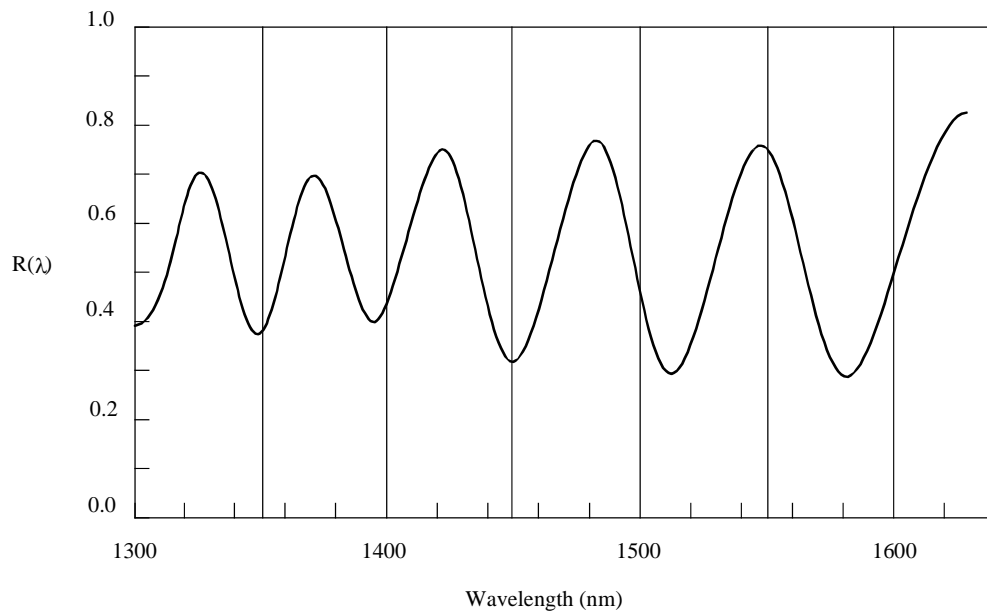

a) Weak mode coupling

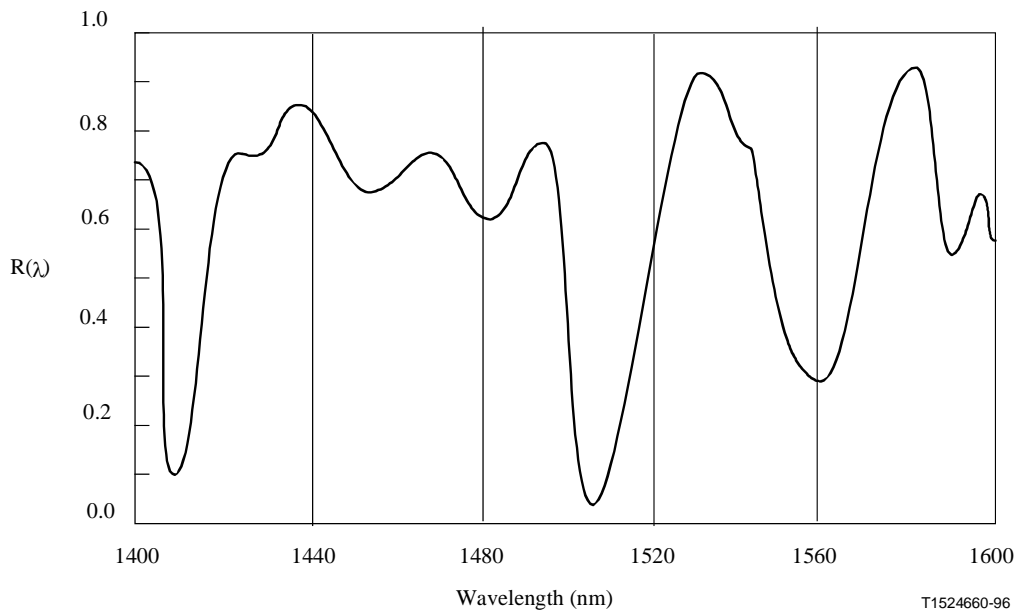

b) Strong mode coupling

Figure 26/G.650 – Typical data obtained in measuring PMD

2.7.2.4 Calculations or interpretation of results

One of the following two methods (2.7.2.4.1 and 2.7.2.4.2) shall be used for calculating PMD from the measurement data.

2.7.2.4.1 Extrema counting

2.7.2.4.1.1 PMD

$R(\lambda)$ should be obtained at evenly spaced wavelength intervals. E is the number of extrema within the window $\lambda_1 < \lambda < \lambda_2$. Alternatively, λ_1 and λ_2 may be chosen to coincide with extrema, in which case E is the number of extrema (including the ones at λ_1 and λ_2) minus one.

$$\langle \Delta\tau \rangle = \frac{k E \lambda_1 \lambda_2}{2 (\lambda_2 - \lambda_1) c} \quad (2-31)$$

where c is the speed of light in vacuum, k is a mode coupling factor which equals 1.0 in the absence of mode coupling (the equation 1-9 regime) and 0.82 in the limit of strong mode coupling (the equation 1-10 regime).

If a polarimeter is used as the detection element, take as the final value of $\langle \Delta\tau \rangle$ the average of the values derived from the three normalized Stokes parameter responses. The value of $\langle \Delta\tau \rangle$ provided by equation 2-31 or the average of the three values of $\langle \Delta\tau \rangle$ derived from polarimetric detection can be used in equation 1-9 or 1-10 (whichever is appropriate for the particular sample) to calculate the PMD coefficient. The resulting value is to be interpreted as an average over the wavelength range $\lambda_1 < \lambda < \lambda_2$.

2.7.2.4.1.2 Accuracy

The best accuracy is obtained by making $(\lambda_2 - \lambda_1)$ large enough to insure that $E \gg 1$. This is especially important when there is strong mode coupling [Figure 26 b)] and less so otherwise [Figure 26 a)]. Values of E in the range of 7 to 40 are typical. When E is at the low end of this range, the percentage of uncertainties in both E and the PMD become large. At the upper end of the range, instrumental broadening may result in some adjacent peaks not being resolved.

Ideally, the scan window should be centred on the fibre's wavelength of use, and the window made wide enough to ensure that E is greater than about 10 for the maximum PMD value of interest (where pass/fail is an issue).

2.7.2.4.1.3 Peak identification

The identification of extrema in $R(\lambda)$ can be more difficult in the presence of noise and/or strong mode coupling. This can be seen in the example of Figure 26 b). An algorithm with the following features is useful in identifying extrema:

- 1) A polynomial is fitted to several adjacent points of $R(\lambda)$ to provide a smoothed curve.
- 2) An extremum is defined as a point where the wavelength derivative of this smoothed curve changes sign.

Additional robustness can be built into the peak identification algorithm if needed.

2.7.2.4.1.4 Spectral resolution

To insure that all features in the optical spectrum are adequately resolved, the spectral resolution $\Delta\lambda$ should satisfy:

$$\Delta\lambda / \lambda < (8\nu\Delta\tau)^{-1} \quad (2-32)$$

where ν is the optical frequency. $\Delta\lambda$ is the instrumental spectral width or the wavelength step size, whichever is larger. For λ in the vicinity of 1550 nm, equation 2-32 reduces to the condition that $\Delta\lambda$ (nm) should be less than the reciprocal of $\Delta\tau$ (ps).

2.7.2.4.2 Fourier analysis

2.7.2.4.2.1 Overview

In this method a Fourier analysis of $R(\lambda)$, usually expressed in the domain of optical frequency, ν , is used to derive PMD. The Fourier transform transforms this optical frequency domain data to the time domain. The Fourier transform yields direct information on the distribution of light arrival times $\delta\tau$. This data is post-processed as described below to derive the expected PMD, $\langle\Delta\tau\rangle$, for the fibre under test. This method is applicable to fibres with weak or strong mode coupling (refer to 2.7.2.4.2.4 and 2.7.2.4.2.5, respectively).

2.7.2.4.2.2 Data pre-processing and Fourier transformation

To use this method, the Fourier transform normally requires equal intervals in optical frequency so that $R(\lambda)$ data is collected (as described in 2.7.2.3) at λ values such that they form equal intervals in the optical frequency domain. Alternatively, data taken at equal λ intervals may be fitted (for example, by using a cubic spline fit) and interpolation used to generate these points, or more advanced spectral estimation techniques used. In each instance, the ratio $R(\lambda)$ at each λ value used is calculated using equations 2-29 or 2-30 as appropriate.

Zero-padding or data interpolation and DC level removal may be performed on the ratio data, $R(\lambda)$. Windowing the data may also be used as a pre-conditioning step before the Fourier transform. The Fourier transformation is now carried out to yield the amplitude data distribution $P(\delta\tau)$ for each value of $\delta\tau$.

2.7.2.4.2.3 Transform data fitting

Fourier transformed data at zero $\delta\tau$ has little meaning since, unless carefully removed, DC components in $R(\lambda)$ may be partially due to insertion loss of the analyser for example. When the DC level is not removed, up to two data points are generally bypassed (not used) in any further calculations. A variable, j , is defined so that the "first valid bin" above zero $\delta\tau$ that is included in calculations corresponds to $j = 0$.

In order to remove measurement noise from subsequent calculations, $P(\delta\tau)$ is compared to a threshold level T_1 , typically set to 200% of the r.m.s. noise level of the detection system. It is now necessary to determine whether the fibre is weakly or strongly mode coupled.

If it is found that the first X valid points of $P(\delta\tau)$ are all below T_1 , this indicates that $P(\delta\tau)$ must have discrete spike features characteristic of weakly coupled fibres. The value of X is equal to three, unless zero-padding is used in the Fourier analysis. In that case, the value of X can be determined from $3 * (\text{number of original data points}) / (\text{total length of array after zero-padding})$. Use subclause 2.7.2.4.2.4 to calculate PMD. If this is not the case, proceed to calculate PMD using subclause 2.7.2.4.2.5 or 2.7.2.4.2.6.

2.7.2.4.2.4 PMD calculation for fibres with weak mode coupling

For a weakly coupled fibre (e.g. a high birefringence fibre) or for a birefringent component, $R(\lambda)$ resembles a chirped sine wave [Figure 26 a)]. Fourier transformation will give a $P(\delta\tau)$ output containing a discrete spike at a position corresponding to the relative pulse arrival time, $\delta\tau$, the centroid of which is the PMD value $\langle\Delta\tau\rangle$.

To define the spike centroid $\langle \Delta\tau \rangle$, those points where $P(\delta\tau)$ exceeds a second predetermined threshold level T_2 , typically set to 200% of the r.m.s. noise level of the detection system, are used in the equation:

$$\langle \Delta\tau \rangle = \frac{\sum_{e=0}^{M'} [P_e(\delta\tau)\delta\tau_e]}{\sum_{e=0}^{M'} [P_e(\delta\tau)]} \quad (2-33)$$

where $M' + 1$ is the number of data points of P within the spike which exceed T_2 . $\langle \Delta\tau \rangle$ in equation 2-33 is typically quoted in picoseconds. If the device under test is a fibre of length L , the PMD coefficient may be calculated using equation 1-9. If no spike is detected (i.e. $M' = 0$), then PMD is zero. Other parameters such as the r.m.s. spike width and/or spike peak value may be reported.

If the device under test contains one or more birefringent elements, more than one spike will be generated. For a number n concatenated fibres/devices, $2^{(n-1)}$ spikes will be obtained.

2.7.2.4.2.5 PMD calculation for fibres with strong mode coupling

In instances of strong mode coupling, $R(\lambda)$ becomes a complex waveform similar to Figure 26 b), the exact characteristics being based on the actual statistics of the coupling process within the fibre/cable. The Fourier transformed data now becomes a distribution $P(\delta\tau)$ representing the autocorrelation of the probability distribution of light pulse arrival times, $\delta\tau$, in the fibre.

Counting up from $j = 0$, determine the first point of P which exceeds T_1 , and which is followed by at least X data points which fall below T_1 . This point represents the last significant point in (i.e. the "end" of) the distribution $P(\delta\tau)$, for a strongly mode-coupled fibre, that is not substantially affected by measurement noise. The $\delta\tau$ value for this point is denoted $\delta\tau_{\text{last}}$, and the value of j at $\delta\tau_{\text{last}}$ is denoted M'' . This fibre is strongly mode coupled. The square root of the second moment, σ_R , of this distribution defines the fibre PMD $\langle \Delta\tau \rangle$, and is given by:

$$\langle \Delta\tau \rangle = \sigma_R = \left\{ \frac{\sum_{j=0}^{M''} [P_j(\delta\tau)\delta\tau_j^2]}{\sum_{j=0}^{M''} [P_j(\delta\tau)]} \right\}^{1/2} \quad (2-34)$$

The $\langle \Delta\tau \rangle$ value given by equation 2-34 is typically quoted in picoseconds. An example of the Fourier transform output obtained in a 25 km fibre with strong mode coupling is shown in Figure 27.

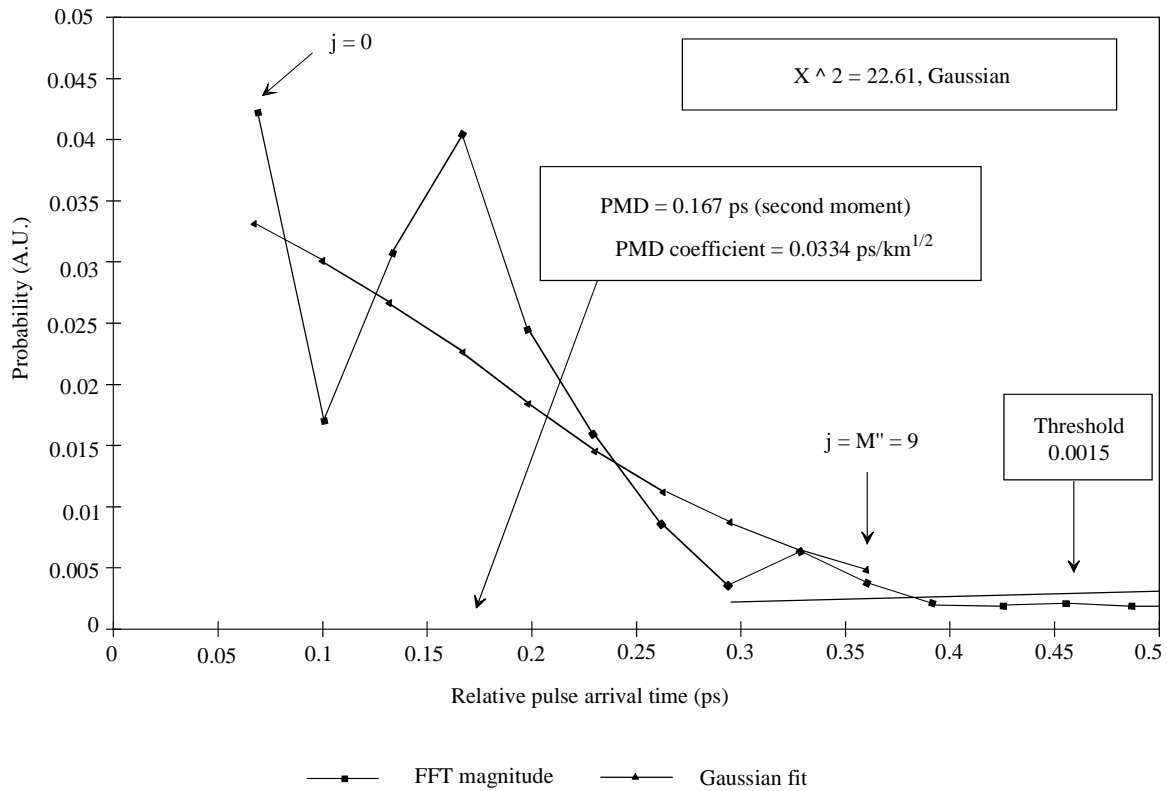

T1524670-96

Figure 27/G.650 – PMD using Fourier analysis

2.7.2.4.2.6 PMD calculation for mixed coupling fibre systems

There may be instances where both weakly coupled fibre/components and strongly coupled fibre(s) are concatenated to form the system under test. In this case, both centroid determination (2.7.2.4.2.4) and the second moment derivation (2.7.2.4.2.5) may be required. Note that spikes in $P(\delta\tau)$ may only be determined beyond the $\delta\tau_{\text{last}}$ computed.

2.7.2.4.2.7 Spectral range

For strongly coupled fibres, sufficient spectral range must be used to form the spectral ensemble (average) with sufficient precision. The statistical uncertainty may be minimized by using the widest possible spectral range (e.g. at least 200 nm). The precision required and therefore spectral range must be specified prior to the measurement. The maximum usable range is limited by the fibre cut-off wavelength (1270 nm or below) at the short (λ_1) end, and by the detector responsivity roll-off at the high (λ_2) end (e.g. 1700 nm).

In addition, very low $\delta\tau$ values will give very long periods in $R(\lambda)$, and the spectral range λ_1 to λ_2 must cover at least two complete "cycles". The spectral range covered defines the smallest $\delta\tau$ value that can be resolved in $P(\delta\tau)$, $\delta\tau_{\text{min}}$:

$$\delta\tau_{\text{min}} = \frac{2\lambda_1\lambda_2}{(\lambda_2 - \lambda_1)c} \quad (2-35)$$

where the factor 2 is introduced to allow for the fact that two data points in P at and adjacent to zero are generally ignored (see 2.7.2.4.2.3). For example, for $\lambda_1 = 1270$ nm, $\lambda_2 = 1700$ nm, $\delta\tau_{\text{min}} = 0.033$ ps.

For weakly coupled high PMD fibres with ratio data $R(\lambda)$ resembling Figure 26 a), the requirement for spectral averaging described above may be relaxed, and the spectral range reduced [e.g. $(\lambda_2 - \lambda_1) \sim 30$ nm] in order to allow variation of PMD with wavelength to be examined.

2.7.2.4.2.8 Wavelength step size and spectral resolution

To ensure that all features (frequencies) in $R(\lambda)$ are adequately resolved, the monochromator step size, expressed in the optical frequency domain ($\Delta\nu$) must be a factor of two smaller than the "oscillation frequency" corresponding to the maximum $\delta\tau$ measured (Nyquist condition):

$$\delta\tau_{\max} = 1 / (2 \cdot \Delta\nu) \quad (2-36)$$

If from the Fourier transform, it is evident that significant energy is present near to $\delta\tau_{\max}$ [i.e. that $R(\lambda)$ appears to be "aliased"], it will be necessary to reduce the step size $\Delta\nu$ (if possible) and repeat the measurement.

The monochromator spectral linewidth (resolution) expressed in optical frequency units is generally equal to or smaller than the smallest $\Delta\nu$ value to be used (corresponding to the largest $\delta\tau$ value to be measured).

For example, for $\delta\tau_{\max} = 1.34$ ps, a monochromator linewidth of 3 nm at 1550 nm ($\Delta\nu = 374$ GHz) is typical.

2.7.2.5 Presentation of the results

- a) Identification of the fibre and/or cable measured.
- b) Test length.
- c) Polarization mode dispersion (typically in picoseconds). If the degree of mode coupling is known, the PMD coefficient may be given in ps/km (negligible mode coupling) or ps/km^{1/2} (strong mode coupling).
- d) The wavelength range over which the measurement was performed, and the wavelength or frequency step size.
- e) The physical configuration of the fibre or cable sample.
- f) Mode coupling type, e.g. deterministic, semi-random or random.
- g) When an average PMD has been obtained from repeated measurements of the sample, record the number of measurements performed.

2.7.3 Test method: Interferometric technique

2.7.3.1 General

This test method describes a procedure for measuring the average polarization mode dispersion of single-mode optical fibres and cables.

The measured value represents the PMD delay (see definition of PMD) over the measurement wavelength range of typically 60 to 80 nanometers in the 1310 nm or the 1550 nm window, depending on the user requirements.

The PMD is determined from the autocorrelation or cross-correlation function of the emerging electromagnetic field at one fibre end when illuminated by a broadband source at the other end. In the case of the autocorrelation type instrument, the interferogram has a central coherence peak corresponding to the autocorrelation of the optical source.

The main advantage of this method is that the measurement time is very fast and the equipment can be easily used in the field.

The dynamics and stability are provided by the well-established Fourier transform spectroscopy technique.

The fibre shall be single mode in the measured wavelength range.

2.7.3.2 Test apparatus

Different implementations are possible. The interferometer can be an air path type or a fibre type, it can be of Michelson or Mach-Zehnder type and it can be located at the source or at the detector end of the device under test. Examples are given in Figures 28, 29 and 30.

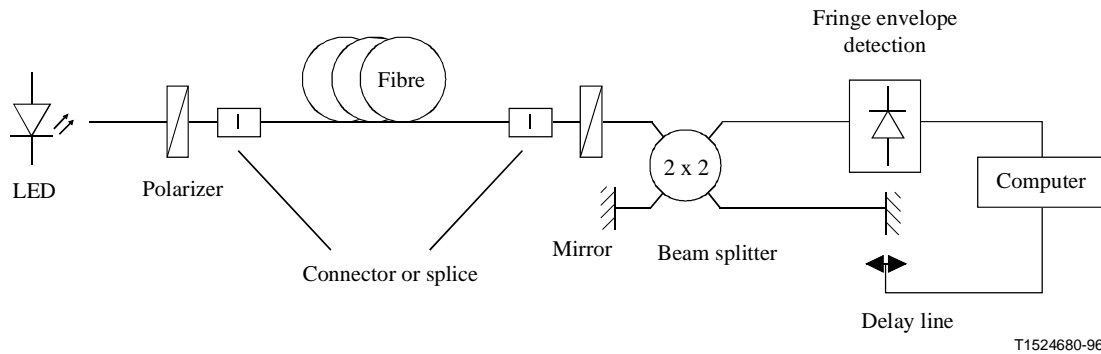

Figure 28/G.650 – The interferometric technique using Michelson interferometer with fibre coupler

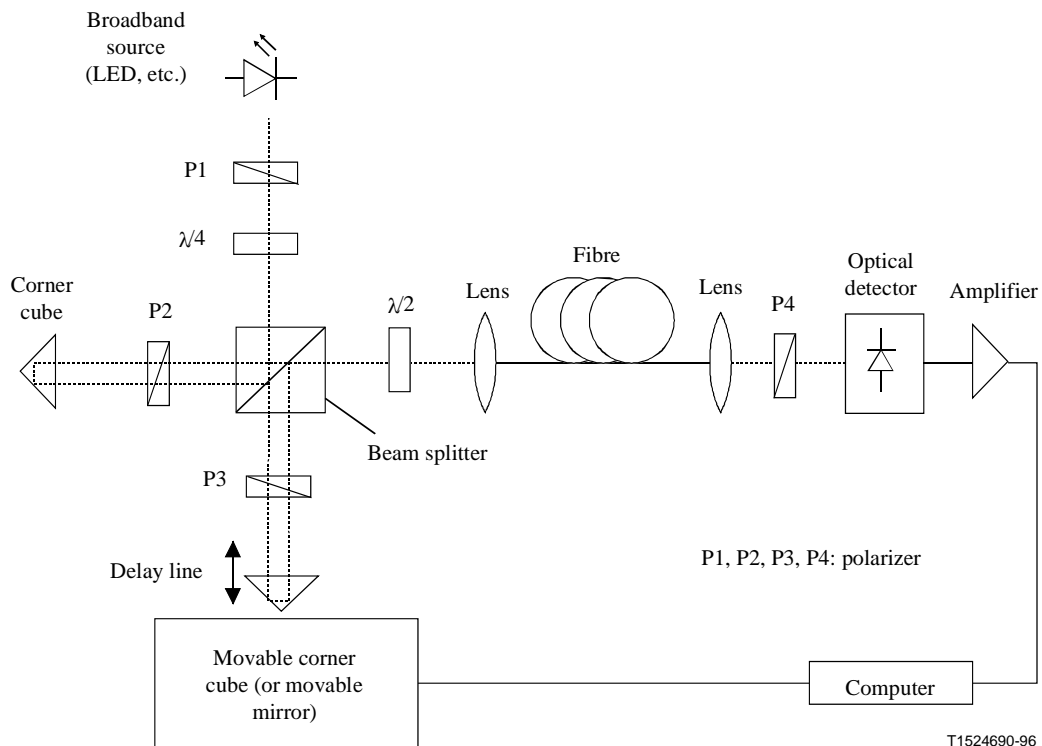
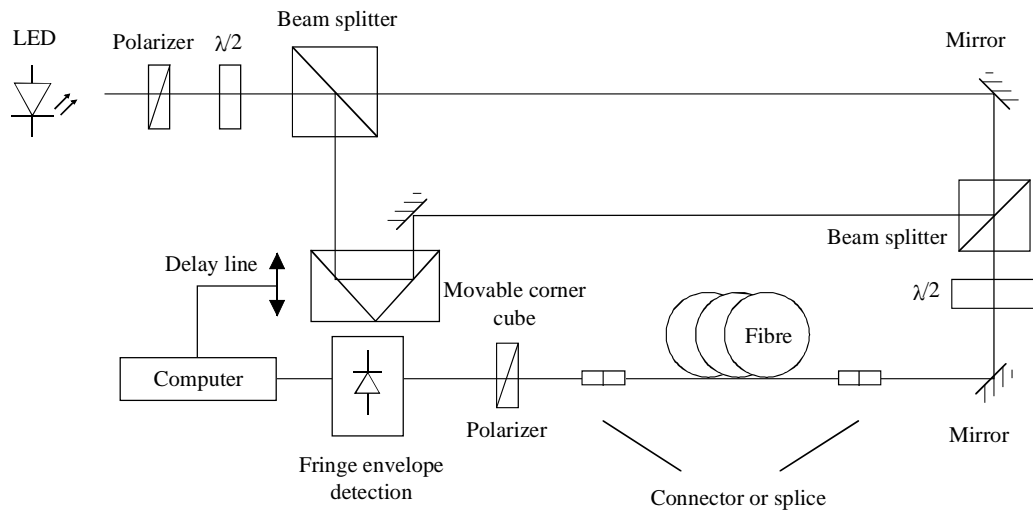

Figure 29/G.650 – The interferometric technique using a Michelson interferometer with an air path



T1524700-96

Figure 30/G.650 – The interferometric technique using a Mach-Zehnder type interferometer with an air path

NOTE – In an autocorrelation interferogram, there is a central autocorrelation peak when the interferometer is balanced [e.g. Figure 31 a), b)]. In contrast, cross-correlation interferograms are obtained when the polarization effects of the two arms of the interferometer are such that the central peak vanishes [e.g. Figure 31 c), d)].

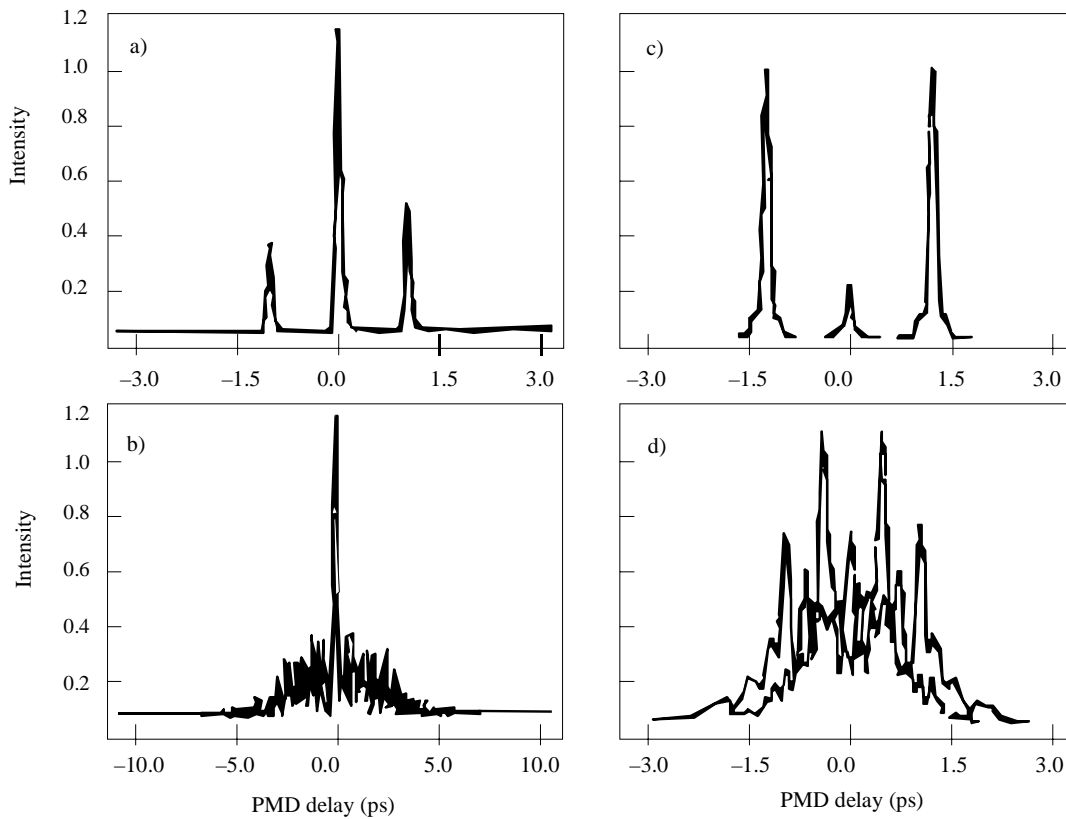

T1524710-96

Figure 31/G.650 – Example of a fringe pattern obtained with the autocorrelation type instrument (a, b) and with the cross-correlation type instrument (c, d) for low (top) and high (bottom) polarization mode coupling

2.7.3.2.1 Optical source

A polarized broad spectrum source, such as a LED followed by a polarizer, shall be used. The central wavelength of the light source shall be within the 1310 nm and/or 1550 nm window. A typical value of its FWHM width is about 60 nm. The spectral shape shall be approximately Gaussian, without ripples which could influence the autocorrelation function of the emerging light.

2.7.3.2.2 Polarizer

The polarizer shall polarize on the full wavelength range of the source.

2.7.3.2.3 Beam splitter

The beam splitter of the interferometer is used to split the incident polarized light into two components propagating in the interferometer's arms. The splitter can be an optical coupler or a cube beam splitter.

2.7.3.2.4 Detector

The light emerging from the fibre under test is coupled to a photodetector whose signal-to-noise ratio is adequate for the measurement. The detection system may include synchronous detection by chopper/lock-in amplifier or comparable techniques.

2.7.3.2.5 Samples

The test sample shall be of known length of single-mode fibre which may or may not be cabled. The sample and pigtails must be fixed in position at nominally constant temperature throughout the measurement. The standard ambient conditions shall be employed. In the case of installed fibres and cables, prevailing deployment conditions may be used.

When it is important to minimize additional mode coupling, uncabled fibre shall be supported in some manner (usually on a reel having a minimum wind radius of 150 mm) with essentially zero fibre tension (loose winding).

Alternative fibre conditions (e.g. fibre shipping spool) may be used in case it has been demonstrated that comparable results are obtained.

NOTE – Although the test sample is normally a fibre, this test can also be performed on discrete components. In this case, PMD coefficient is not relevant.

2.7.3.2.6 Data processing

For the analysis of the interference pattern a computer with suitable software shall be used.

2.7.3.3 Measurement procedure

One end of the fibre under test is coupled to the polarized output of the polarized light source. The other end is coupled to the interferometer input shown in Figure 28 or Figure 30, or to the detector through the lens and polarizer shown in Figure 29. This can be done by standard fibre connectors, splices or by a fibre alignment system. If the latter is used some index matching oil avoids reflections.

The optical output power of the light source is adjusted to a reference value characteristic for the detection system used. To get a sufficient fringe contrast, the optical power in both arms shall be almost identical.

Make a first acquisition in moving the mirror of the interferometer arm and recording the intensity of the light. From the obtained fringe pattern for one selected state of polarization, the PMD delay can be calculated as described below. A typical example of a fringe pattern for low and high polarization mode coupling is shown in Figure 31.

In case of insufficient PM coupling or in case of low PMD, it is recommended to repeat the measurement for different polarization states or to modulate the polarization state during the measurement in order to obtain a result which is an average over all polarization states.

2.7.3.4 Determination of polarization mode dispersion

2.7.3.4.1 Weak mode coupling

In the case of weak mode coupling the PMD delay is determined from the separation of the two satellite coherence peaks, each delayed from the centre by the differential group delay of the device under test. For this case the DGD is equivalent to the PMD delay.

$$\Delta\tau = \frac{2\Delta L}{c} \quad (2-37)$$

where ΔL is the moving path of the optical delay line and c the light velocity in free space.

2.7.3.4.2 Strong mode coupling

In the case of strong mode coupling the determination of the PMD delay is based on the width of the fringe pattern interferogram. The PMD delay, $\Delta\tau$, is determined from the width parameter, σ , of the Gaussian curve fitting the interferogram according to:

$$\Delta\tau = \sqrt{\frac{3}{4}}\sigma \quad (2-38)$$

NOTE – σ is the standard deviation of the Gaussian curve.

Appendix II gives an example of an algorithm to determine the PMD delay $\Delta\tau$ from an interferogram. It can often be shown that the ratio of σ_ε to σ is a consistent value, which allows an alternative substitution. Other algorithms are possible, i.e. those based on cumulative integration.

For the algorithm in Appendix II, the typical measurement range is 0.1-100 ps. Other algorithms may allow this measurement range to be extended.

2.7.3.5 Equipment calibration

The equipment is calibrated by checking the mechanics of the delay line with a high birefringent fibre of known PMD delay. Another possibility is the use of a "golden fibre" with known PMD.

2.7.3.6 Presentation of the results

- a) Date.
- b) Fibre identification.
- c) Fibre type.
- d) Fibre length.
- e) Test set-up arrangement, including source type, wavelength, linewidth (FWHM).
- f) Launching technique.
- g) Type of fringe detection technique.
- h) Plot over the scanned range with fringe pattern (only if mode coupling type is not random).
- i) Fibre deployment and environmental conditions (radius, stress, temperature, etc.).
- j) Mode coupling type (random, semi-random or deterministic).
- k) PMD delay in ps and PMD coefficient. If the degree of mode coupling is known, the coefficient may be given in ps/km or ps/ $\sqrt{\text{km}}$.
- l) Other special conditions.

2.7.4 Principal state of polarization (PSP) methods

2.7.4.1 General

This method is restricted to the wavelength region of actual single-mode operation of the fibre. It can be applied to both short and long fibres, regardless of the degree of polarization mode coupling.

The method is based on the fact that when the optical frequency of the launched light is varied, the polarization state at the output of the fibre, represented on the Poincaré sphere in the space of the Stokes parameters, rotates around the axis coinciding with the direction of the PSPs at a rate dependent on the PMD delay: the greater the delay, the faster the rotation. Therefore by measuring the rotation angle $\Delta\theta$ of the representative point on the Poincaré sphere corresponding to angular frequency variation $\Delta\omega$ the PMD delay, $\delta\tau$, is obtained as:

$$\delta\tau = \left| \frac{\Delta\theta}{\Delta\omega} \right| \quad (2-39)$$

It should be noted that when one of the input PSPs is excited, the corresponding SOP at the fibre output remains unchanged by definition and no rotation is detected on the Poincaré sphere.

The technique provides directly the Differential Group Delays (DGDs) between the principal states of polarization of the fibre under test as a function of wavelength or time. The PMD is obtained by suitable averaging over time or wavelength or both. The method is able to give complete information about the statistics of the DGDs.

2.7.4.2 Test apparatus

A schematic diagram of the test apparatus is shown in Figure 32. The technique involves measuring the output state of polarization of the fibre under test at a number of wavelengths across a given spectral range by launching in the fibre under test light with fixed state of polarization.

2.7.4.2.1 Optical source

A stable single-line laser, tunable across the measurement wavelength range, is required. The spectral width of the laser must be narrow enough to ensure that depolarization of the signal due to the PMD of the fibre under test does not occur.

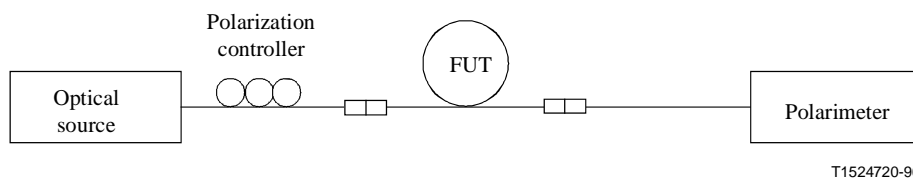

Figure 32/G.650 – Schematic of the apparatus for PMD measurement by state of polarization analysis

2.7.4.2.2 Polarization controller

A polarization controller shall be placed between the optical source and the fibre under test.

2.7.4.2.3 Polarimeter

A polarimeter to measure the Stokes parameters as a function of wavelength at the output of the fibre under test shall be used.

2.7.4.2.4 Samples

The test sample shall be of known length of single-mode fibre which may or may not be cabled. The sample and pigtails must be fixed in position at nominally constant temperature throughout the measurement. The standard ambient conditions shall be employed. In the case of installed fibres and cables, prevailing deployment conditions may be used.

When it is important to minimize additional mode coupling, uncabled fibre shall be supported in some manner (usually on a reel having a minimum wind radius of 150 mm) with essentially zero fibre tension (loose winding).

Alternative fibre conditions (e.g. fibre shipping spool) may be used in case it has been demonstrated that comparable results are obtained.

NOTE – Although the test sample is normally a fibre, this test can also be performed on discrete components. In this case, PMD coefficient is not relevant.

2.7.4.3 Measurement procedure

2.7.4.3.1 Measurement

- a) The light exiting the optical source is passed through the polarization controller and coupled to the fibre under test. The polarization controller is set so as to optimize the conditions for the determination of the rotation angle on the Poincaré sphere, if necessary. If the paths are in fibre, provide that the fibres are stationary during the measurements to follow.
- b) The output of the fibre under test is coupled to the input of the polarimeter.
- c) Select the wavelength range over which the measurement is to be performed.
- d) Select the wavelength step $\Delta\lambda$ (in nm) at which Stokes parameters are to be measured. To avoid that the output state of polarization (PSP) rotates more than 180° about the PSPs axis on the Poincaré sphere from one test wavelength to the next, the requirement $\Delta\tau_{\max} \Delta\lambda \leq 4$ ps.nm should be fulfilled, where $\Delta\tau_{\max}$ (in ps) is the maximum expected DGD of the fibre under test.
- e) The measured values of the Stokes parameters at the selected wavelengths value are recorded in a way suitable for the analysis described in the following subclauses.

2.7.4.3.2 Poincaré Sphere (PS) method

- a) The trace on the Poincaré sphere describing the evolution of the State of Polarization (SOP) with wavelength shall be reconstructed from measured Stokes parameters (S_0 , S_1 , S_2 and S_3). S_0 , S_1 , S_2 and S_3 relate to the total optical power, the linear SOP of $\theta = 0^\circ$, the linear SOP of $\theta = 45^\circ$ and the right circular SOP, respectively. In Figure 33, (o) and (x) are SOP arcs of measured values due to PMD as a function of wavelength λ . Here, P_{a-a} is Principal States of Polarization (PSP).

The trace shall be analysed piecewise, considering wavelength intervals (which may include more than two wavelength steps) such that the assumptions ensuring the existence of well-determined PSPs hold. The local PSP axis on the Poincaré sphere and the corresponding rotation angle $\Delta\Phi$ caused by the considered wavelength variation $\Delta\lambda$ are then determined by means of simple geometrical considerations. A possible procedure could be the analysis of the trace on the Poincaré sphere by considering the measured points three by three and finding the point of intersection of the axes of the segments identified by the two pairs of points. Starting from this point, it is possible to calculate the value of $\Delta\Phi$ by means of trigonometric relationships.

The DGD or PMD $\delta\tau$ is given by:

$$\delta\tau = \frac{\Delta\Phi}{2\pi\Delta f} = \frac{\Delta\Phi\lambda_1\lambda_n}{2\pi c\Delta\lambda} \quad (2-40)$$

where $\Delta\Phi$, Δf and c are the phase difference (Stokes vector arc on the Poincaré sphere), frequency difference and light velocity in free space, respectively, and λ_1 and λ_n are the initial and final wavelength of $\Delta\lambda$, respectively.

- b) The DGD (in ps) shall be calculated as a function of wavelength. Data can also be displayed in a histogram form, by plotting the distribution of frequency of occurrence of measured DGD values.
- c) The mean value of the measured DGDs, $\langle\delta\tau\rangle_\lambda$ shall be calculated over the considered wavelength range. To increase the sample size, multiple measurements can be performed.
- d) The PMD coefficients shall be calculated by suitable normalization of the measured mean value of DGD $\langle\delta\tau\rangle_\lambda$ to the length L (in km) of the fibre under test, typically square root kilometre units.

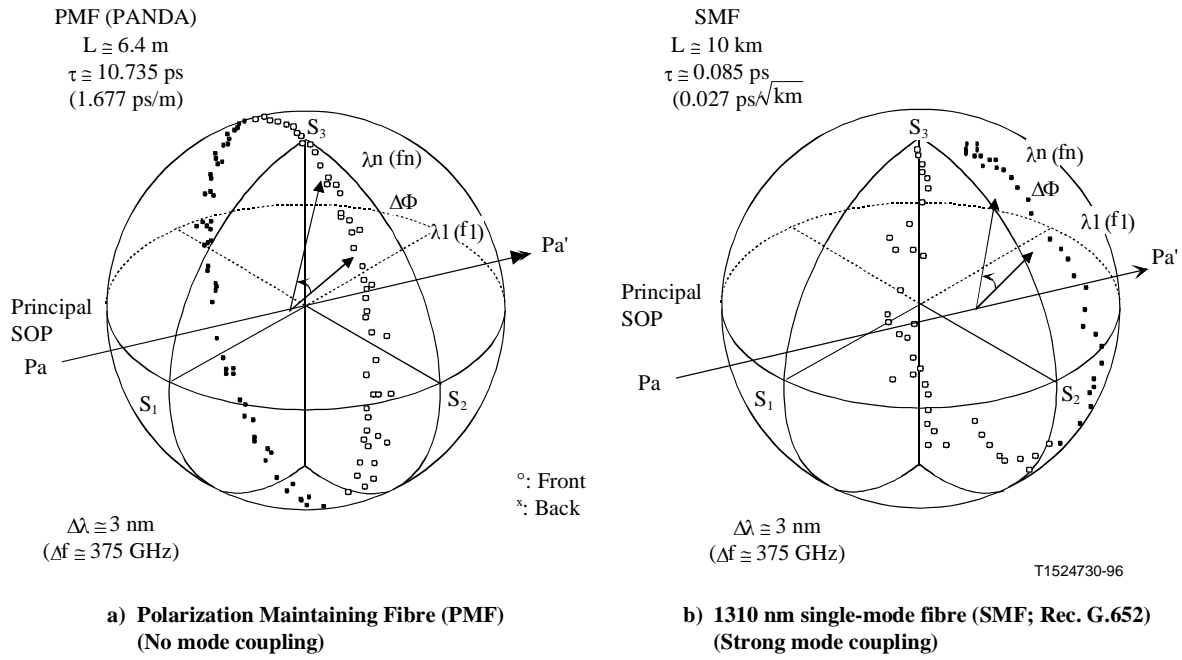

Figure 33/G.650 – Poincaré sphere representation of two examples of PMD measurements

2.7.4.3.3 State of Polarization (SOP) method

After the polarization fluctuation was measured by Stokes analyser (or rotatable analyser), it can be transformed into the SOP curve as a function of wavelength (frequency).

The SOP is expressed as:

$$SOP = \frac{1 - \eta^2}{1 + \eta^2} \quad (2-41)$$

where:

$$\eta = \tan \left[0.5 \tan^{-1} \left\{ S_3 / \sqrt{S_1^2 + S_2^2} \right\} \right] \quad (2-42)$$

Here, η is the polarization ellipticity, S_1 , S_2 and S_3 are Stokes parameters.

In Figure 34, the peak (or extrema) to peak of SOP curves is equivalent to the phase difference of π .

The DGD or PMD $\delta\tau$ is given by:

$$\delta\tau = \frac{N}{2} \cdot \frac{1}{\Delta f} = \frac{N}{2} \cdot \frac{\lambda_1 \lambda_n}{c \Delta\lambda} \quad (2-43)$$

where N represents the numbers from extrema to extrema of SOP curves.

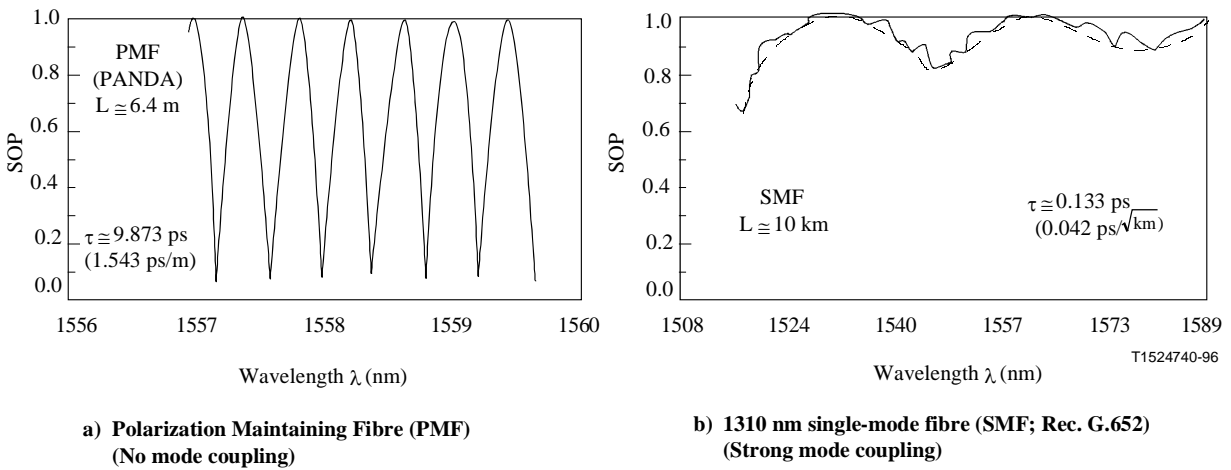

Figure 34/G.650 – State of Polarization (SOP) representation of two examples of PMD measurements

2.7.4.4 Presentation of the results

- a) Test set-up arrangement, processing algorithms.
- b) Wavelength range, wavelength step, number of sampled points.
- c) Temperature of the sample and environmental conditions.
- d) Fibre identification and length.
- e) Fibre deployment conditions.
- f) Indication of the accuracy and repeatability.
- g) Plot of the accuracy and repeatability.
- h) Histogram of the measured DGDs versus wavelength (if required).
- i) Mean DGD.
- j) PMD coefficient.

APPENDIX II

Determination of PMD delay from an interferogram

This Appendix presents a method to determine the PMD delay from an interferogram with an autocorrelation peak in the centre as shown in Figure II.1.

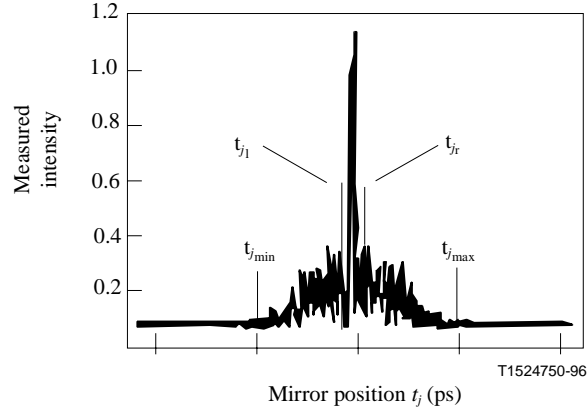

Figure II.1/G.650 – Parameters for interferogram analysis

Let \tilde{I}_j denote the measured intensity of the interferogram at increasing positions t_j , $j = 1 \dots N$, with $[t_j] = \text{ps}$.

Step 1 – Computation of the zero intensity \tilde{I}_0 and the noise amplitude Na

Definition: $N_5 = \text{round}(5N/100)$

$$\tilde{I}_0 = \frac{\sum_{j=1}^{N_5} (\tilde{I}_j + \tilde{I}_{N-j})}{2N_5} \quad (\text{II-1})$$

$$X_2 = \frac{\sum_{j=1}^{N_5} (\tilde{I}_j^2 + \tilde{I}_{N-j}^2)}{2N_5} \quad (\text{II-2})$$

$$Na = \sqrt{X_2 - I_0^2} \quad (\text{II-3})$$

Step 2 – Definition of the shifted intensity I_j

$$I_j := \tilde{I}_j - \tilde{I}_0 \quad \text{if } \tilde{I}_j - \tilde{I}_0 > 4Na \quad (\text{II-4})$$

$$I_j := 0 \quad \text{if } \tilde{I}_j - \tilde{I}_0 \leq 4Na \quad (\text{II-5})$$

Step 3 – Computation of the centre C of the interferogram

$$C = \frac{\sum_{j=1}^N t_j I_j}{\sum_{j=1}^N I_j} \quad (\text{II-6})$$

Step 4 – Removal of the central autocorrelation peak

Definition: $j_l :=$ the largest index j such that $C - t_j > \tau_c$ (II-7)

$j_r :=$ the smallest index j such that $t_j - C > \tau_c$ (II-8)

where τ_c is the source coherence time.

NOTE 1– For cross-correlation interferograms, the following definition shall be applied:

$$j_r := j_l + 1 \quad (\text{II-9})$$

Step 5 – Computation of the second moment S of the interferogram

$$S = \frac{1}{2} \left\{ \sqrt{\frac{\sum_{j=1}^{j_l} (t_j - C)^2 I_j}{\sum_{j=1}^{j_l} I_j}} + \sqrt{\frac{\sum_{j=j_r}^N (t_j - C)^2 I_j}{\sum_{j=j_r}^N I_j}} \right\} \quad (\text{II-10})$$

Step 6 – Truncate the interferogram

Set j_{\min} to the largest index j such that $C - t_j > 2S$ (II-11)

Set j_{\max} to the smallest index j such that $t_j - C > 2S$ (II-12)

Step 7 – Computation of the second moment σ_ε of the truncated interferogram

$$\sigma_\varepsilon = \frac{1}{2} \left\{ \sqrt{\frac{\sum_{j=j_{\min}}^{j_l} (t_j - C)^2 I_j}{\sum_{j=j_{\min}}^{j_l} I_j}} + \sqrt{\frac{\sum_{j=j_r}^{j_{\max}} (t_j - C)^2 I_j}{\sum_{j=j_r}^{j_{\max}} I_j}} \right\} \quad (\text{II-13})$$

Step 8 – Computation of the σ of the Gaussian $e^{-\frac{(t-C)^2}{2\sigma^2}}$ such that

$$\sigma_\varepsilon = \frac{1}{2} \left\{ \sqrt{\frac{\int_{t_{j_{\min}}}^{t_{j_l}} (t - C)^2 e^{-\frac{(t-C)^2}{2\sigma^2}} dt}{\int_{t_{j_{\min}}}^{t_{j_l}} e^{-\frac{(t-C)^2}{2\sigma^2}} dt}} + \sqrt{\frac{\int_{t_{j_r}}^{t_{j_{\max}}} (t - C)^2 e^{-\frac{(t-C)^2}{2\sigma^2}} dt}{\int_{t_{j_r}}^{t_{j_{\max}}} e^{-\frac{(t-C)^2}{2\sigma^2}} dt}} \right\} \quad (\text{II-14})$$

Step 9 – Determination of PMD delay $\Delta\tau$

$$\Delta\tau = \sqrt{\frac{3}{4}}\sigma \quad (\text{II-15})$$

NOTE 2 – For appropriately measured interferograms, it can be shown that $\frac{\sigma_\varepsilon}{\sigma} \approx \sqrt{\frac{3}{4}}$.